

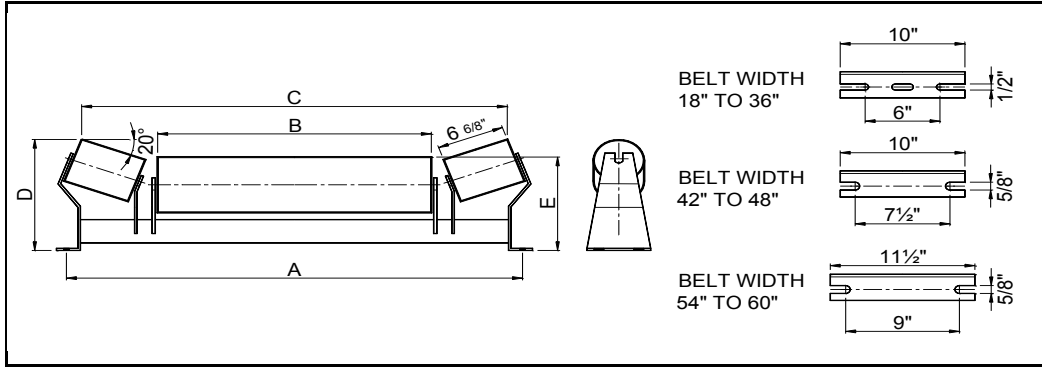

## 20° PICKING IDLER



### 4" ROLL

BELT WIDTH	IDLER PART NUMBER	ROLL PART NUMBER	A	B	C	D	E $\frac{1}{4}$ " $\pm$	IDLER WEIGHT	ROLL WEIGHT	IDLER ROTATING WEIGHT	SHAFT $\varnothing$	BRG TYPE
24	MC4-2420-PIC	MC-PC-4-24	33	15 3/8	30 1/4	10 1/4	8	58	15	28	1-1/4" - 1	6205
30	MC4-3020-PIC	MC-PC-4-30	39	21 1/8	36	10 1/4	8	66	20	32	1-1/4" - 1	6205
36	MC4-3620-PIC	MC-PC-4-36	45	27 1/8	42	10 1/4	8	82	32	35	1-3/8" - 1-1/8	6306
42	MC4-4220-PIC	MC-PC-4-42	51	33 1/8	48	10 3/4	8 1/2	90	38	48	1-3/8" - 1-1/8	6306
48	MC4-4820-PIC	MC-PC-4-48	57	39 1/8	54	10 3/4	8 1/2	99	45	57	1-3/8" - 1-1/8	6306
54	MC4-5420-PIC	MC-PC-4-54	63	45 1/8	60	11	8 3/4	108	51	63	1-5/8" - 1-1/8	6306
60	MC4-6020-PIC	MC-PC-4-60	69	51 1/8	66	11	8 3/4	117	59	67	1-5/8" - 1-1/8	6306

### 5" ROLL

BELT WIDTH	IDLER PART NUMBER	ROLL PART NUMBER	A	B	C	D	E $\frac{1}{4}$ " $\pm$	IDLER WEIGHT	ROLL WEIGHT	IDLER ROTATING WEIGHT	SHAFT $\varnothing$	BRG TYPE
24	MC5-2420-PIC	MC-PC-5-24	33	15 3/8	30 1/4	10 3/4	8 1/2	60	18	30	1-1/4" - 1	6205
30	MC5-3020-PIC	MC-PC-5-30	39	21 1/8	36	10 3/4	8 1/2	69	24	34	1-1/4" - 1	6205
36	MC5-3620-PIC	MC-PC-5-36	45	27 1/8	42	10 3/4	8 1/2	85	35	44	1-3/8" - 1-1/8	6306
42	MC5-4220-PIC	MC-PC-5-42	51	33 1/8	48	11 1/4	9	93	41	48	1-3/8" - 1-1/8	6306
48	MC5-4820-PIC	MC-PC-5-48	57	39 1/8	54	11 1/4	9	102	48	57	1-3/8" - 1-1/8	6306
54	MC5-5420-PIC	MC-PC-5-54	63	45 1/8	60	11 1/2	9 1/4	116	60	71	1-5/8" - 1-1/8	6306
60	MC5-6020-PIC	MC-PC-5-60	69	51 1/8	66	11 1/2	9 1/4	126	67	75	1-5/8" - 1-1/8	6306

### 6" ROLL

BELT WIDTH	IDLER PART NUMBER	ROLL PART NUMBER	A	B	C	D	E $\frac{1}{4}$ " $\pm$	IDLER WEIGHT	ROLL WEIGHT	IDLER ROTATING WEIGHT	SHAFT $\varnothing$	BRG TYPE
24	MC6-2420-PIC	MC-PC-6-24	33	15 3/8	28 1/4	11 1/2	9	67	21	34	1-1/4" - 1	6205
30	MC6-3020-PIC	MC-PC-6-30	39	21 1/8	34	11 1/4	9	77	28	39	1-1/4" - 1	6205
36	MC6-3620-PIC	MC-PC-6-36	45	27 1/8	40	11 1/4	9	94	41	53	1-3/8" - 1-1/8	6306
42	MC6-4220-PIC	MC-PC-6-42	51	33 1/8	46	11 3/4	9 1/2	103	48	62	1-3/8" - 1-1/8	6306
48	MC6-4820-PIC	MC-PC-6-48	57	39 1/8	52	11 3/4	9 1/2	113	55	69	1-3/8" - 1-1/8	6306
54	MC6-5420-PIC	MC-PC-6-54	63	45 1/8	58	12	9 3/4	129	69	83	1-5/8" - 1-1/8	6306
60	MC6-6020-PIC	MC-PC-6-60	69	51 1/8	64	12	9 3/4	139	77	90	1-5/8" - 1-1/8	6306

#### NOTES :

1. Also available with wide mounting centers = A + 6"
2. Dimensions in Inches, Weights in lbs
3. Specify 'center' or 'wing' rollers when ordering replacement rollers
4. The part number for a frame only is the idler part number with the suffix FR
5. Wing rollers  $\varnothing 5$ " or  $\varnothing 6$ " - 6-6/8" Face -  $\varnothing 1$ " Shaft - 6205 Bearing

Information subject to change without notice. Certified information available upon request