

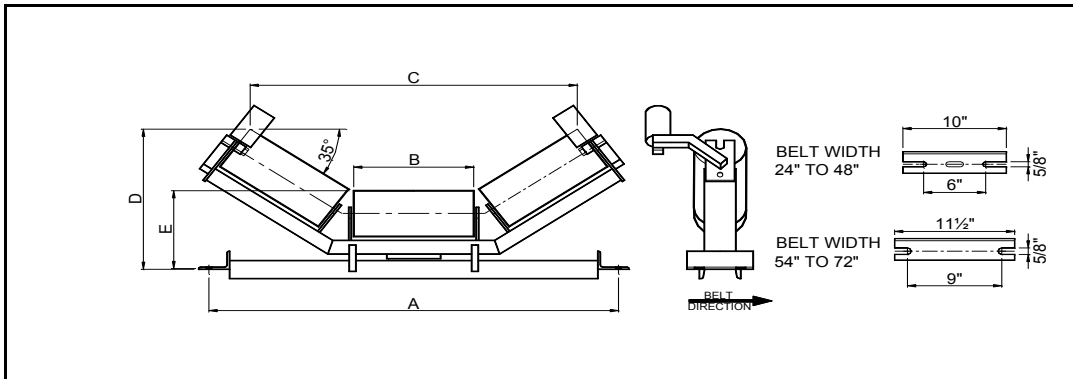

35° TROUGH SELF ALIGNING IDLER



5" ROLL

BELT WIDTH	IDLER PART NUMBER	ROLL PART NUMBER	A	B	C	D	E ± 1/4"	IDLER WEIGHT	ROLL WEIGHT	ROLL ROTATING WEIGHT	SHAFT Ø	BRG TYPE
24	MD5-2435-TSA	MD-TR-5-24	33	9 1/2	26	14 3/4	9	78	15	12	1	6305
30	MD5-3035-TSA	MD-TR-5-30	39	11 3/8	31 1/4	15 3/4	9	94	16	13	1	6305
36	MD5-3635-TSA	MD-TR-5-36	45	13 3/8	36 1/4	17	9	105	18	14	1-1/4* - 1	6305
42	MD5-4235-TSA	MD-TR-5-42	51	15 3/8	41 1/2	18 1/2	9 1/2	118	20	16	1-1/4* - 1	6305
48	MD5-4835-TSA	MD-TR-5-48	57	17 3/4	47 3/4	20	9 1/2	130	22	17	1-1/4* - 1	6305
54	MD5-5435-TSA	MD-TR-5-54	63	19 3/4	53	21 1/4	9 3/4	176	24	18	1-1/4* - 1	6305
60	MD5-6035-TSA	MD-TR-5-60	69	22	59 1/4	22 3/4	9 3/4	185	26	20	1-1/4* - 1	6305
72	MD5-7235-TSA	MD-TR-5-72	81	26	69 1/2	25 1/4	10	196	30	22	1-1/4* - 1	6305

6" ROLL

BELT WIDTH	IDLER PART NUMBER	ROLL PART NUMBER	A	B	C	D	E ± 1/4"	IDLER WEIGHT	ROLL WEIGHT	ROLL ROTATING WEIGHT	SHAFT Ø	BRG TYPE
24	MD6-2435-TSA	MD-TR-6-24	33	9 1/2	25 1/4	15 1/4	9 1/2	88	18	15	1	6305
30	MD6-3035-TSA	MD-TR-6-30	39	11 3/8	30 1/2	16 1/4	9 1/2	106	20	17	1	6305
36	MD6-3635-TSA	MD-TR-6-36	45	13 3/8	35 3/4	17 1/2	9 1/2	118	23	19	1-1/4* - 1	6305
42	MD6-4235-TSA	MD-TR-6-42	51	15 3/8	40 3/4	19	10	132	25	20	1-1/4* - 1	6305
48	MD6-4835-TSA	MD-TR-6-48	57	17 3/4	47	20 1/2	10	146	28	23	1-1/4* - 1	6305
54	MD6-5435-TSA	MD-TR-6-54	63	19 3/4	52 1/4	21 3/4	10 1/4	194	30	24	1-1/4* - 1	6305
60	MD6-6035-TSA	MD-TR-6-60	69	22	58 1/2	23 1/4	10 1/4	205	33	27	1-1/4* - 1	6305
72	MD6-7235-TSA	MD-TR-6-72	81	26	68 3/4	25 3/4	10 1/2	220	38	30	1-1/4* - 1	6305

NOTES :

1. These idlers also available with 20°, 35° and 45° trough angles
2. Also available with wide mounting centers = A + 6"
3. Trough idlers have 3 equal length fully interchangeable rollers.
4. The part number for a frame only is the idler part number with the suffix FR
5. Dimensions in Inches, Weights in lbs
6. Note actual belt height will be approximately 5/8" larger than standard for correct tamer operation
7. * 1-1/4" diameter shaft stepped-down to 1" diameter at the bearing.

NB. The CEMA D standard for bolt centers is 6" for 24" to 36" belts, and 7-1/2" for 42" to 48" belts.

Our slots are open-ended allowing full compatibility from 24" to 48" belts, for 6" and larger than 7-1/2" bolt centers.

There is an additional central slot allowing for a single bolt option on 24" and up to 48" belt widths.

Information subject to change without notice. Certified information available upon request